



Early-BOD Test Kit

User Guide

General Limited Warranty

CheckLight warrants the products manufactured by the Company, against defects and workmanship when used in accordance with the applicable instructions for a period not to extend beyond the product's printed expiration date. CheckLight makes no other warranty, expressed or implied. There is no warranty of merchantability or fitness for a particular purpose.

Copyright 2009 CheckLight Ltd

Table of contents

	page
1- Introduction	5
What Is the Biochemical Oxygen Demand (BOD) Assay?	5
How Does the Kit Work?	6
What is Included in the Kit	6
Reagents Provided	6
Equipment and reagents Required	7
2 - Preparing For the Assay	8
Important Factors That May Affect an Assay	8
Cleanliness	8
Accuracy	9
Reagent Freshness and Storage	9
Preparing the Carbon Cocktail Solution	9
Sample Collection and Storage	9
3- Assay Procedure	10
Outline of the Assay Procedure	10
Equipment and Reagents Required	11
Test Procedure 1- Standard	12
Sample Pre-Treatment	12
Prepare the Biosensor-Bacteria	12
Label the tubes	12
Add Assay Buffer to the Sample	12

Dilute the Sample	13
Prepare Negative Controls	13
Prepare Positive Controls	13
Dispense Biosensor Bacteria	14
Incubate & Measure Luminescence	14
Calculate BOD Concentration	14
Scheme	15
Test Procedure 2- Micro plate format	16
Sample Pre-Treatment	16
Prepare the Biosensor Bacteria	16
Label the tubes	16
Add Assay Buffer to the Sample	16
Dilute the Sample	17
Prepare Negative Controls	17
Prepare Positive Controls	17
Prepare & Dispense Biosensor Bacteria	18
Incubate & Measure Luminescence	18
Calculate BOD Concentration	18
Scheme	19
Estimating the concentration of BOD	20
Notes	21
4 - Troubleshooting	22
5 - Frequently Asked Questions	23

1-Introduction

About This Manual

This manual contains the instructions for how to use the Early-BOD Test Kit. The kit is easy to use and provides quick accurate results as long as the instructions are followed. It is therefore very important that you read and understand all of this manual **before** starting the assay.

If you encounter any problems while performing the assay read over *Factors That May Affect an Assay* on page 8, and find a list of problems that you may encounter in *Troubleshooting* page 22.

What Is the Biochemical Oxygen Demand (BOD) Assay?

Biochemical oxygen demand (BOD) is an international regulatory environmental index for monitoring organic pollutants in wastewater and the current legislated standard test for BOD monitoring requires 5 days to complete (BOD5 test). Because of the 5-day lag, BOD5 results are seldom of any use for real time process adjustment or decision making.

CheckLight developed a unique technology for determination of BOD in water in only 3-4 hours. Data analysis is straightforward: the higher the luminescence, the higher the concentration of utilizable carbon. Acquiring this vital information in real time enables timely corrective measures in waste water processing, and elimination of risk of heavy fines due to BOD limit excess.

The kit is for screening water from sources such as

- Sewage
- Reclaimed water
- Industrial water effluents

How Does the Kit Work?

The BOD kit is based on using light-producing (luminous) bacteria as very sensitive and accurate biosensors. The idea behind the assay is simple:

The non-assimilable organic compounds are first hydrolyzed by a mild HCl pre-treatment. This treatment breaks down polymers into assimilable oligomers and monomers. CheckLight's specially formulated reagent is then exposed to the treated sample, and luminescence is recorded after 1-3 hours of incubation. The level of luminescence is proportional to the concentration of utilizable organic carbon in the sample.

What is Included in the Kit

The following materials are provided with the kit. Make sure that all are present before proceeding with the assay:

Reagents Provided

- Biosensor - Stoppered vials holding freeze-dried luminous bacteria
- Hydration Buffer
- Concentrated Assay Buffer (only in the micro plate version)
- Assay Buffer
- Concentrated (X100) carbon cocktail-standard solution (5 mg/ml)
- Empty tubes

Equipment and Reagents Required

- 10-1000 pipettor and tips
- Repeat dispenser with 0.01ml aliquots (syringe or tip)
- Luminometer (minimum sensitivity of 1 fmol ATP)
- Temperature-controlled water bath
- Timer
- Vortex
- Clean water - Use nano-pure reference water that is <5ppb TOC, such as Milli-Q Element/Gradient/Synthesis Grade.
- Cork-screw 10mL glass tubes (for boiling tested water samples)
- 10N HCl, 10N NaOH, 2M MOPS (4-Morpholinepropanesulfonic acid) buffer, pH 7
- Please see section 1.6 in the Early BOD-Application Guide, for preparation tips.



We recommend that you use the provided Excel sheet for rapid and simple data analysis.

2 - Preparing For the Assay

Important Factors That May Affect an Assay

The accuracy of the results can be affected by a number of factors. It is very important to keep these factors in mind while performing the assay.

Cleanliness

Due to the high sensitivity of the assay, care should be taken to keep all vials, plastic tips, and pipettes extremely clean. Keep in mind the following do and don't list:

Do

- Wash the plastic tips several times with clean water before use
- Work in a clean manner to keep the reagents from getting contaminated

Do not:

- Do not touch tips and inner side of tubes with bare hands to reduce the risk of contamination.
- Do not reuse the test vials
- Do not wash pipettors, pipette tips or glassware with detergent, acids or solvents. Use water only.

Accuracy

Due to the great sensitivity of the kit it is very important to add the reagents in exactly the right amounts. Therefore:

- Make sure that the pipette tip is firmly attached to the pipettor each time you add a reagent
- Before pipetting double-check that the pipettor is set to the correct amount.
- Check that there are no air bubbles inside the pipette tip.

Reagents Freshness and Storage

Make sure that all reagents are stored under appropriate conditions both in storage and after preparation.

Biosensor: a freeze-dried preparation of an isolated variant of the marine luminous bacteria *Vibrio harveyi*. The shelf life of this reagent is one year when stored in a deep freezer (-10°C to -20°C). Reagent should not be stored in a self-defrosting freezer, which defrosts by warming up periodically. Once hydrated in Hydration Buffer, the suspended cells can be used within 4 hours, if kept on ice, or at 4°C.

Assay Buffers – the Assay Buffer is provided in two forms – concentrated (x8) (provided only in micro plate format kit) and dilute (ready to use Buffer. Referred to as :”Assay Buffer”). The solution has a natural yellowish color. The buffers, together with the Hydration Buffer, should be kept at 4°C and should not be frozen.

Preparing the Carbon Cocktail Solution

The 5 ppm Carbon Cocktail Solution must be prepared fresh daily

- Add 0.1 ml of the 5 mg/ml (5000 ppm) stock into 0.9 ml Assay Buffer (Solution A; 500 ppm).
- Mix well by carefully pipetting up and down.
- Prepare another tube with 0.99 ml of buffer and dispense into it 0.01 ml from Solution A (Solution B; 5 ppm).
- Mix well by carefully pipetting up and down.

Sample collection and storage

Sampling follows the same procedure as for the standard BOD5 method.

3 - Assay Procedure

Outline of the Assay Procedure

The assay is performed in the following steps:

- Prepare all reagents and equipment
- Collect the sample
- Pre-treat the sample at 100°C
- Warm the water bath to 28°C
- Hydrate biosensor bacteria and incubate for 30 minutes at 28°C
- Label 14 empty tubes
- Mix Assay buffer and sample in first tube
- Dispense Assay Buffer to remaining 13 tubes
- Perform dilution of sample into 5 tubes
- Leave 3 tubes as negative controls
- Prepare positive control dilutions in four remaining tubes
- Add Biosensor to tubes
- Incubate for 60-150 minutes
- Read results
- Calculate BOD value

Equipment and Reagents Required

- 14 empty vials
- 15 ml assay buffer
- 1 ml carbon cocktail solution
- One vial of freeze dried biosensor bacteria
- Pipettor and tips
- Repeat dispenser
- Temperature-controlled water bath
- Incubator
- Luminescence reader
- Nano pure reference water <5ppb such as Milli-Q Element/Gradient/Synthesis grade
- Cork-screw 10mL glass tubes (for boiling tested water samples).
- 10N HCl, 10N NaOH. 2 M MOPS (4 Morpholine propane sulfonic acid) buffer, pH 7
- Please see section 1.6 in the Early BOD-Application Guide, for preparation tips.

Test Procedure 1 - Standard

Sample Pre-Treatment

- Incubate 1 mL of the sample in a screw-cap borosilicate tube containing 0.1 ml HCl (10N). Loosely screw back the cap and incubate the tube in a beaker containing boiling water for 60 minutes (keep the water in a boiling state throughout the incubation period).
- Cool down the tube and add sequentially:
 - 0.1 ml of 10 N NaOH
 - 0.8 ml of 2M MOPS (pH 7).
- Mix well. Make sure final pH is ~ 7.0.

Prepare the Biosensor Bacteria

- Hydrate the lyophilized bacteria by adding 0.5 ml of cold Hydration Buffer.
- Vortex. If lumps appear discard the vial.
- Incubate for 30 minutes at 28°C prior to use.

Label the Tubes

Sequentially label 14 tubes and put them in a rack.

Add Assay Buffer to the Sample

- Add 0.4 ml of the treated sample to tube #1.
- Add 1.6 ml of Assay Buffer (note - at this point, concentration of the sample is 10%).
- Mix by vortexing.

Dilute the Sample

- Add 1 ml of Assay Buffer to tubes #2-#14.
- Add 1 ml from the solution in tube #1 to tube #2.
- Mix well.
- Repeat this dilution step through tubes #3, 4, 5, 6, and 7.
- Discard 1 ml from tube #7.

Prepare Negative Controls

- Leave tubes #8, 9 and 10 as negative controls (containing Assay Buffer only).
- Mix well.

Prepare Positive Controls

- Prepare 1 ml of Carbon Cocktail Solution diluted in Assay Buffer to a final concentration of 5ppm.
- Dispense as follows:

Tube #	Amount (μ l)	Final Concentration (ppb)
11	10	50
12	20	100
13	40	200
14	80	400

- Mix well

Dispense Biosensor Bacteria

After the bacteria have been incubated for 30 minutes at 28°C (See *Prepare the Biosensor Bacteria*, page 12), use a repeat pipettor to dispense 10 µl of the bacterial solution into all tubes. Incubate the tubes at 28°C.

Measure Luminescence

Place the luminometer next to the water bath. Measure the luminescence at two time points, about one hour apart (take the first reading when the two lowest concentrations of the positive control set emit significantly higher luminescence (>3XSD) than the negative control).

Calculate BOD concentration

Using the Excel spreadsheet record the results obtained and calculate the BOD concentration.

If the BOD concentration in the original sample is very high, the linear range of response may not fall within the 10%-0.15% dilution set range. In such case, you should pre-dilute the sample and run a new dilution set (for example, instead of mixing 0.4ml of the treated sample with 1.6ml of assay buffer in tube #1, mix 0.04ml treated sample with 1.96ml buffer, so that the dilution set will now run from 1% down to 0.01%).

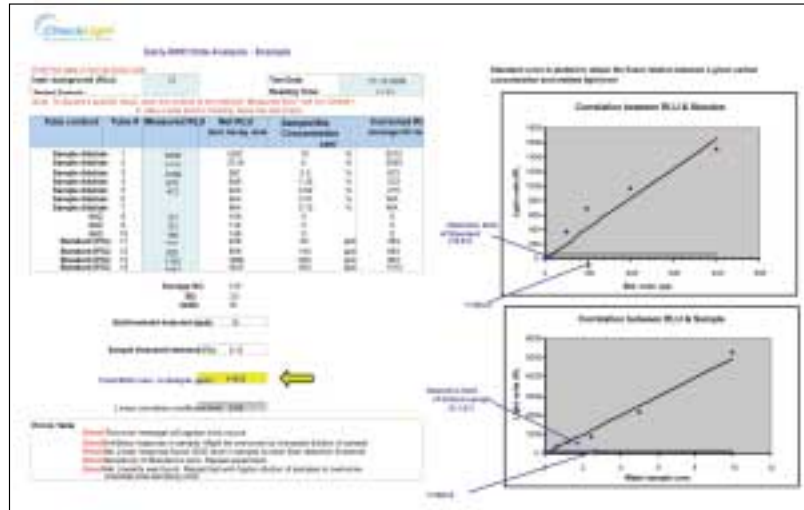

EARLY-BOD Test

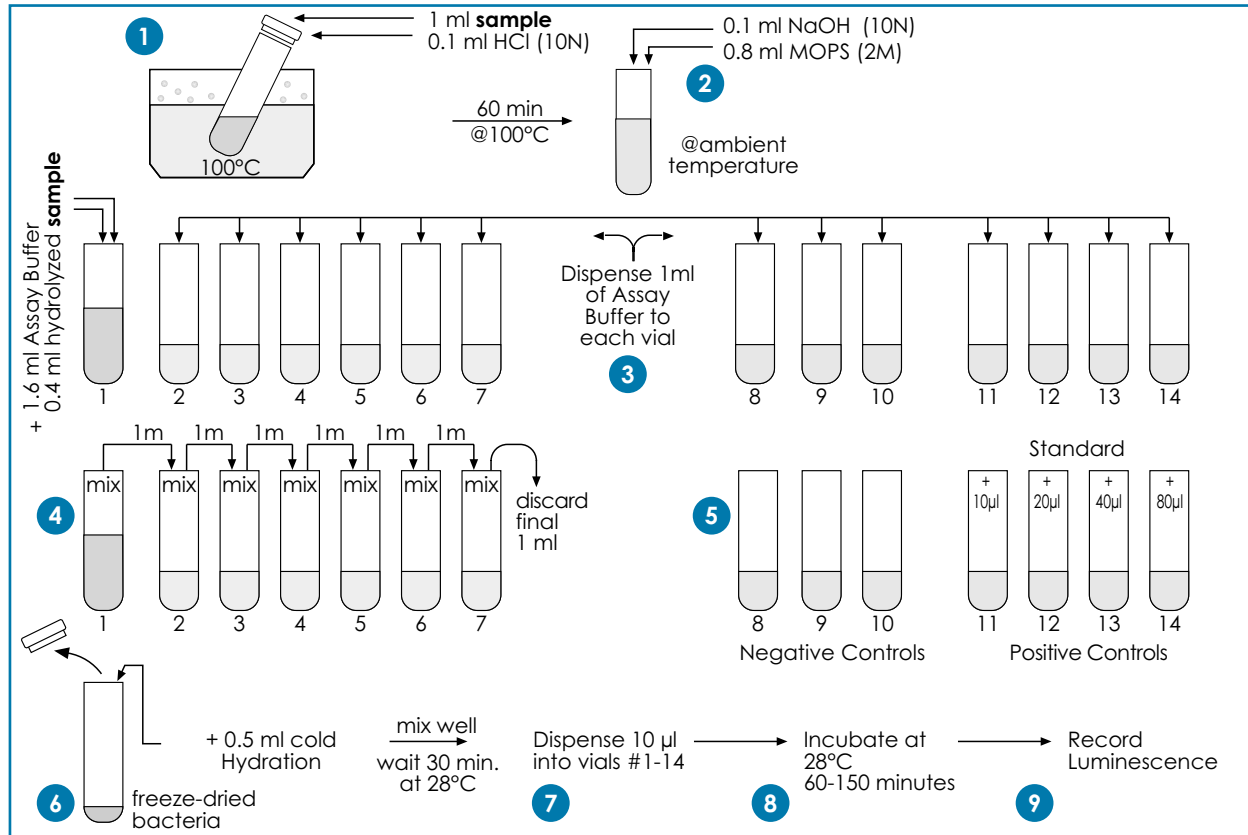

Test Procedure 2 – Micro Plate Format

Sample Pre-Treatment

- Incubate 1 mL of the sample in a screw-cap borosilicate tube containing 0.1 ml HCl (10N). Loosely screw back the cap and incubate the tube in a beaker containing boiling water for 60 minutes (keep the water in a boiling state throughout the incubation period).
- Cool down the tube and add sequentially:
 - 0.1 ml of 10 N NaOH
 - 0.8 ml of 2M MOPS (pH 7)
- Mix well. Make sure final pH is ~ 7.0.

Prepare the Biosensor Bacteria

- Hydrate the lyophilized bacteria by rapidly adding 0.3 ml of cold Hydration Buffer.
- Vortex without the stopper. If lumps appear discard the vial.
- Incubate for 30 minutes at 28°C prior to use.

Add Assay Buffer to the Sample

- Add 0.262 ml of the treated sample to well #1.
- Add 0.037 ml of concentrated Assay Buffer.
- Mix by pipetting up and down 3 times.

Dilute the Sample

- Add 0.15 ml of diluted Assay Buffer to wells #2 - #14.
- Add 0.15 ml from the solution in well #1 to well #2.
- Mix well by pipetting up and down 3 times.
- Repeat this dilution step through wells #3, 4, 5, 6, and 7.
- Discard 0.15 ml from well #7.

Prepare Negative Controls

- Leave wells #8, 9 and 10 as negative controls (containing diluted Assay buffer only).
- Mix well by pipetting up and down.

Prepare Positive Controls

- Prepare 1 ml of Carbon Cocktail Solution diluted in Assay Buffer to a final concentration of 5 ppm.
- Remove from well #13 and wells #14, 5 and 10.
- Dispense as follows:

Well #	Amount (μ l)	concentration (ppb)
11	1	30
12	3	90
13	5	150
14	10	300

- Mix well by pipetting up and down 3 times.

Dispense Biosensor Bacteria & Incubate

- After the bacteria have been incubated for 30 minutes at 28°C (See *Prepare Biosensor Bacteria* on page 15), Add 0.7 ml of Assay Buffer. Mix.
- Use a repeat dispenser to dispense 10 µl into each well. Place the plate within the plate reader (or air incubator) with a temperature set at 28°C.

Measure Luminescence

Measure the luminescence after 60-150 minutes (or when the tubes with the two lowest concentrations emit significantly higher luminescence (>2XSD) than the negative control).

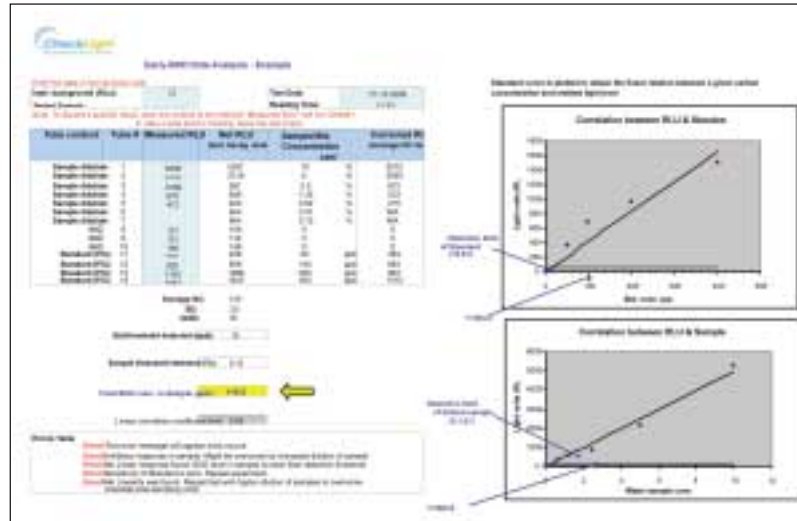

Calculate BOD concentration

Using the Excel spreadsheet record the results obtained and calculate the BOD concentration in the sample.

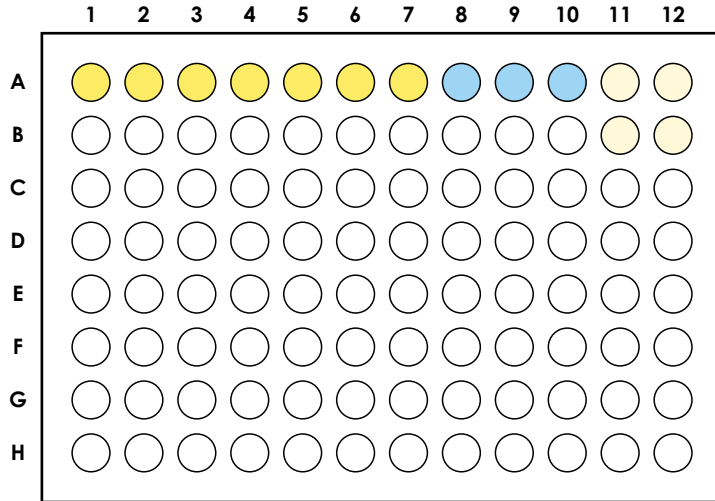

Test Procedure 2 – Micro plate format



-  Positive control set
-  Negative control
-  Sample dilution set

Note - Be sure to use an opaque polypropylene plate

Estimating The Concentration of BOD in the Tested Water Sample Using the Excel Module

The module performs the following calculations automatically:

1. Calculate the average reading of the negative controls (ANC) and Standard Deviation (SD).
2. Subtract the ANC from all readings.
3. Calculate the minimal concentration of the sample (in %) that exhibited an increase of (3xSD) in luminescence over the control. Note that the water concentration in tube #1 – 10%; tube#2 – 5%, etc.
4. Determine the (3xSD) of the Carbon Cocktail Standard by graphically plotting the luminescence obtained in each sample against its concentration. The detected sensitivity should be around 10-20 ppb.
5. The (3xSD) values obtained for the tested sample and the standard solution are defined as having an equivalent BOD value.
Thus, for example, if 10% water and 20ppb Carbon Cocktail Solution were defined as the (3xSD) concentrations, the BOD of the sample is said to contain $20\text{ppb} \times 10 = 0.2\text{ppm}$ Carbon equivalent units.
6. In order to convert carbon equivalent units into the commonly used BOD units (mg glucose/Liter), one should run several samples in both standard and CheckLight methods to determine the correlative coefficient factor for all future tests with that water source. Alternatively, one could regard the carbon equivalent units as arbitrary units for comparison between BOD values obtained from different water sources.

Notes:

- When calculating the BOD levels choose the time point that exhibits the optimum sensitivity as compared to the standard. Do not calculate the average obtained at different reading time points.
- If one of the three negative control tubes exhibits a result that is significantly different than the other two, discard the result and calculate the average of the remaining two tubes.
- Hydrate the bacteria in cold Hydration Buffer.
- When running a large number of samples take a reading of the controls at the beginning and end of the process as luminescence may increase with time.
- The range of sample dilution (the number of tubes in the dilution set) can be changed according to estimated concentration of BOD in the original sample, but should include at least 3 tubes

4 - Troubleshooting

Problem	Possible Fault	Corrective action
Inconsistent results	<ul style="list-style-type: none">• Inaccurate pipetting of reagents• Insufficiently mixed• Inconsistent incubation time and temperature	<ul style="list-style-type: none">• Make sure not to draw air bubbles• Make sure to use a repeat dispenser to aliquot the bacteria• Make sure to keep test conditions steady (e.g., incubation temperature, mixing, & reading time)
Positive controls are not working	<ul style="list-style-type: none">• Improper dilution of the stock solution• Inaccurate dispensing of bacteria	<ul style="list-style-type: none">• Make sure the stock solution is prepared as instructed on page 9• Use a repeat dispenser to aliquot the bacteria
Luminescence levels obtained in the first vials of the dilution set are lower than those recorded in the more diluted samples.	<ul style="list-style-type: none">• This might indicate that the sample contains toxic elements. Various curves may appear when plotting sample dilution versus luminescence, depending on the level of BOD and concentration of toxicant.	<ul style="list-style-type: none">• Try increasing the dilution of the sample. If linear range of response is obtained, then inhibition in higher concentration can be disregarded.

5 - Frequently Asked Questions

Q: Are luminous bacteria dangerous? Do I need to be a trained microbiologist in order to be able to conduct CheckLight's assays?

A: Luminous bacteria are not pathogenic and are harmless. No special skill is required to carry out the different tests other than very basic laboratory techniques (pipetting, dilutions etc) and equipment (pipettor, tips, luminometer).

Q: How does the test correlate with the standard BOD5 method?

A: The graph below depicts an example of the correlation obtained between the two tests using samples taken from a municipal waste treatment plant.

Q: What are the benefits of obtaining rapid information on BOD levels?

A: Acquiring this vital information in real time enables timely corrective measures in waste water processing, and elimination of risk of heavy fines due to BOD limit excess.

Q: What are the advantages of using this test over the standard COD test?

A: Chemical Oxygen Demand measures the

Correlation between the standard BOD5 test and CheckLight's BOD test

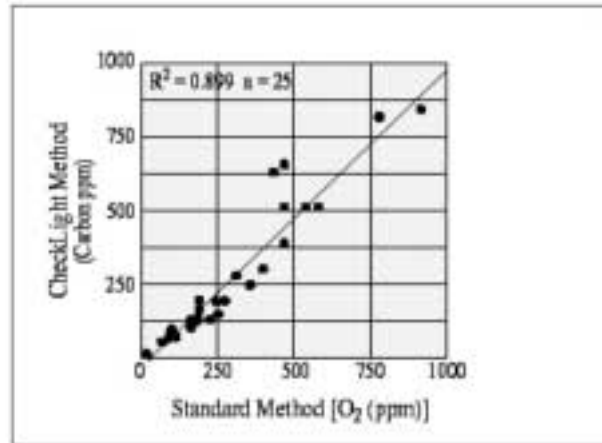

ability of hot chromic acid solution to oxidize organic matter. This analyzes both biodegradable and non-biodegradable (refractory) organic matter. The COD test can be completed in a few hours, but the results of the test are usually higher than the corresponding BOD test for several reasons. Many organic compounds which are dichromate oxidizable are not biochemically oxidizable - certain inorganic substances, such as sulfides, sulfites, thiosulfates, nitrites and ferrous iron are oxidized by dichromate, creating an inorganic COD, which is misleading when estimating the organic content of the wastewater. Moreover, the COD test is limited in sensitivity and requires the addition of toxic chemicals such as mercury to eliminate interferences such as chloride between estimated BOD and measured BOD. The luminescence-based BOD test truly measures the ability of the bacteria to digest the organic matter present in the sample.

Q: Why is there a control in each assay?

A: Readings of the negative control are needed in order to obtain the background reading of the cells without the sample. In addition, a set of positive controls is run in order to calibrate the system and provide the proper “translation” of light units to carbon equivalent units.

Q: Can I “play around” with the volumes of bacteria, buffers and other assay conditions?

A: No. It is extremely important to follow the test protocol instructions to the word. Since the test is very sensitive, any seemingly minor variations result in poor reliability.

Q: Can I reuse the provided test vials?

A: Due to the high sensitivity of the assay, care should be taken to keep all vials, plastic tips, and pipettes extremely clean. Do not reuse test vials and do not wash glassware pipettors or pipette tips with detergent, acid, or solvents.

Q: What is the shelf life of the reagents?

A: The shelf life of the freeze dried bacteria is one year when stored in a deep-freezer (-10°C to -20°C). Reagent should not be stored in a self-defrosting freezer, which defrosts by warming up periodically. The assay buffers should be stored in a regular refrigerator (4°C) and under no circumstances should they be frozen.



P.O.Box 72 Qiryat-Tivon 36000, Israel
Tel: +972 4 9930530, Fax: +972 4 9533176
www.checklight.biz
